

Are you ready to...

***Save Money On Your
Fuel Bills***

**Build Your Own
Electric Car
Or Truck**



By
Les and Jane Oke

©Les and Jane Oke- 2008

***** IMPORTANT *****
Please Read this First

If you have any Problems, Questions or Concerns about this book, please contact us immediately.

Use the [Contact](#) form on our website .

We want you to know that you are important to us. Your success is important to us. That makes your questions important to us.

Your total satisfaction with this book is our aim.

Please remember that it does take some time to digest new information. There are times when it takes me 2 or even 3 times reading a book before I 'get it'.

You are not alone if you don't get it the first time through. This can be a very complicated subject to understand, especially if it is new to you. Take your time and let us help you if you need it.

We are here to help you and we will walk you through every step if you need us to.



Authors- Les and Jane Oke will answer any and all question you may have.

Table of Contents

Preface – What will you need to get started and how will you begin.

Chapter One – Finding a vehicle to convert. Using Cars or trucks is covered and where to find them.

Chapter Two – Electric Motors, where to find them, AC vs DC, Advantages , Transmission considerations. Finding free electric motors is covered too.
Helpful websites too.

Chapter Three – Controllers for motors is covered, where to find them and which one is best.

Chapter Four – Finding free batteries for your electric car conversion, how do you figure out the overall range of your vehicle too.

Chapter Five – Many other components are necessary to make your electric car conversion work, we explore the diverse list of components.
A parts list is covered too.

Chapter Six -Getting started with your conversion. Let's take off the exhaust and the fuel system.

Let's carefully take out that old gas motor too.

Measuring once, and getting it right.

What about the power brakes and power steering?

Chapter Seven - Electric motor mounting is next. Where does it go and how is it supported?

Chapter Eight - Battery positioning is next, safety and layout considerations are all covered.

How are they held in place? Supports and laying out the design. Wire routing is covered.

Chapter Nine – Final layout of the controller and charger. Schematic drawings to get it right.

Chapter Ten – Starting up your vehicle the first time. Safety concerns and having an expert check it out first. Let's go.

Our Mission- Your Purpose **And A bit of History...**

Our mission is very simple- we will show you how to build your own electric car with detailed plans and pictures that any handyman or woman could follow.

Congratulations on your investment in **How to Build An Electric Car**. We know you will have as much fun building your own as we did.

Back in 1994 our family moved off the grid to use only Renewable Energy to power our home. That decision has proven to be a good one for our family both financially and environmentally.

We use mainly wind generators and solar panels that we built ourselves. You can read about these building projects later.

After much research into the design and building of wind generators and battery systems it hit me one day like a brick. *Why not use the same renewable energy technology to run our car, our off road vehicle or any vehicle for that matter?*

We had found sources of free industrial batteries, inexpensive DC motors and simple building techniques that anyone could use. The same sources could be used to build an electric car.

All the best,

Les and Jane

The Building Begins

This is not an original idea, to build an electric car; the idea has existed for many years. This is, however an original plan for building an electric car using inexpensive sources of parts and simple building techniques.

One problem we met with was finding larger DC motors that were powerful enough to run a car, but we did find them and we will share them with you shortly.

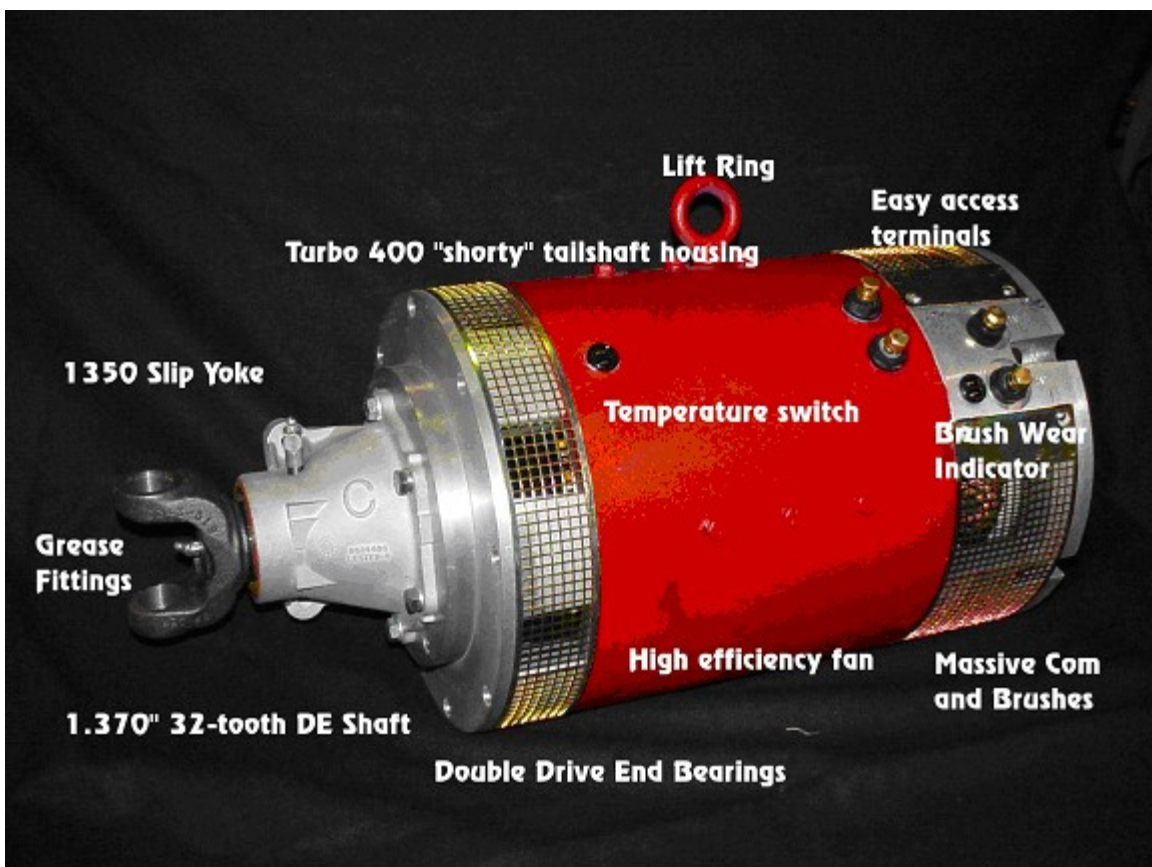

You should know that the process can get technical at times. For that reason we, again recommend reading and rereading the plans until you get it. If you need help a friendly local mechanic or in our case the local high school shop (tech) teacher was a big help in designing this vehicle.

Build Your Own Electric Car Challenge

Here at our off grid home we are always looking for new and better ways to use renewable energy in our lives. We took on this project as a challenge to all of those people who said it could not be done.

We want to share this information with as many people as we can; the suppression of knowledge in the area of alternative fuels for vehicles has gone on too long. That is why we are in the energy crunch we now face. The electric car is the answer we think. You will find out why very soon.

We had seen electric cars and hybrid electric vehicles on the roads for a few years and we knew that with our experience in the field of Renewable Energy, especially DC motors and battery systems that we could make it work.

What Will You Learn?

- Convert your car to electric for under \$500
- Sources of free industrial batteries
- Safe installation of batteries and all parts
- Documented conversion of our vehicle with pictures
- Sources of DC motors and controllers
- Sources of Electric Car Conversion kits
- Where to find the right car or truck to start with
- An off road electric vehicle conversion
- Your electric car will travel 60 mph
- You will be able to drive up to 100 miles between charges
- Renewable Energy charging options

Parts List To Get Started

You will need a minimum amount of tools at the very least, a small work space area (we used a 10 foot by 20 foot shop for most of our work). It doesn't need to be very large.

Tools Needed

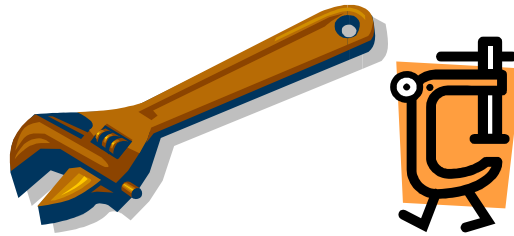

Jigsaw, small grinder, various wrenches, socket set, various screw drivers, #80 sand paper. Work bench, welding equipment and a hoist and a big pile of initiative mostly.

Simple Wiring Diagram

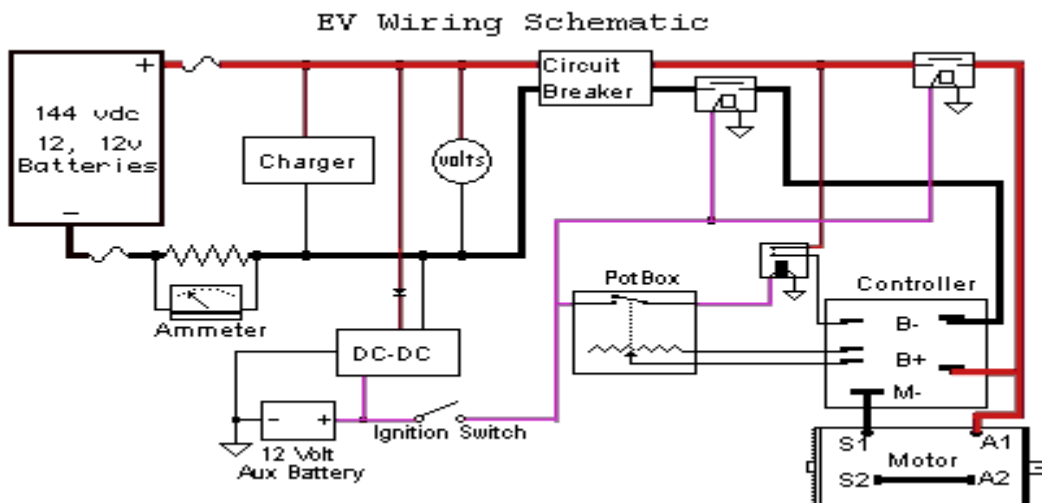

Parts List

Motor – AC or DC
Motor Controller
Manual disconnect
Motor adaptor
Main contactor
Inertia switch
Charger
Battery ends
DC-DC power supply
Amp meter shunt
E-Meter or several digital meters
Fuses
Throttle control box
Battery cables
Cable cutters (a must as they cut the cable properly)
Lugs
Battery ends
A crimping tool to install cable ends
Vacuum pump (to bleed power brakes)
Batteries
Battery boxes (make your own)
Misc. nuts and bolt etc.

Before we get started let's answer some frequently asked questions to set your mind at ease about this project.

Q: Why Convert your car to electric in the first place?

Answer-

The first reason is the environment. Toxic fumes, greenhouse gas, toxic waste, you name it we have put it in the environment with our cars. Car and truck exhaust is one of the biggest contributors to air pollution that has ever existed. We all know that car companies have been forced to clean up their act, to a point. But, simple emission controls are not the answer.

Finding new ways to fuel our cars is the answer. Using renewable energy to power our cars is the answer that we are pursuing here.

An electric vehicle produces very close to zero emissions, which is an excellent solution. You can use conventional AC power from your home, which is more and more produced with renewable energy sources or...

You can do as we have done and set up your vehicle charging system to be run completely from the sun and the wind. It is the right choice that we can all make.

The Cost of Driving. Even if you can only charge your car with your own AC home outlets, it will only cost about \$1 per charge. How far will \$1 of gasoline take you?

Gasoline prices vary widely, but you can be sure it costs less to run your car on electricity.

We will show you ways to charge your vehicle with renewable energy sources as well, which will make your driving even cheaper.

Dependence on Foreign Oil. For most of us we are not personally connected with the oil industry, but in the back of

our heads is always that nagging question- when will it all end?

How can we keep using so much oil, the supply has to be finite and run out eventually. What will we do then?

Why not work on solving the problem now?

Practical Simplicity. Have you looked under the hood of your car lately? There are more bells and whistles all run by computer than the average person could figure out in a year, or perhaps a lifetime. I know I can't.

An electric motor has only one part that moves, it is simple and will run for hundreds of thousands of miles with hardly even looking at it.

Just think, no more fiddly things to fix all the time that break on your car. No more exhaust system and no more gasoline leaks. No more oil changes, and no more engine breakdowns or maintenance.

You can use this new technology, which is available to you today to convert your own vehicle to electric.

What if we let the government fix the problem? Do we really have that much time? Climate change and global warming are reducing our world to a shambles every day. We have to take action now to reduce our dependence on oil.

Reducing the number of vehicles dependent on gas is a great way to start.

Have you seen the number of large SUV's and trucks that the government continues to let American auto makers build. There are literally millions of dollars invested in the internal combustion engine and those dollars can't be reinvested.

The system has to change, the large car companies can do this, but why wait?

Let's get started



You can get started now at: [Convert2EV](#)

[Build Your Own Electric Car Website](#)